

Bubble Master Operators Manual



Please Read Carefully Before Operating

Table of Contents

Page 1	Technical Specifications
Page 2	Warning
Page 3	Operating Procedure
Page 4	BubbleMaster Control Features
Page 5	Shut Down Procedure
Page 5	Trouble Shooting the BubbleMaster
Page 6	Maintenance
Page 6	Safety Precautions
Page 7	Warranty
Page 8	Accessories

Technical Specifications

Model: BubbleMaster

Type: Water Base Bubble generating system

Size: 723 x 412 x 406 mm. High (Incl. Bubble Projector)
28 1/2" x 16 " x 16 1/4" High (Incl. Bubble Projector)

Weight: 21 Lbs. 9.51 Kg.

Power Rating: 115 Volt A.C. 50/60 Hz 1 Amps
220 Volt A.C. 50/60 Hz 0.5 Amps

BubbleMaster Illustration

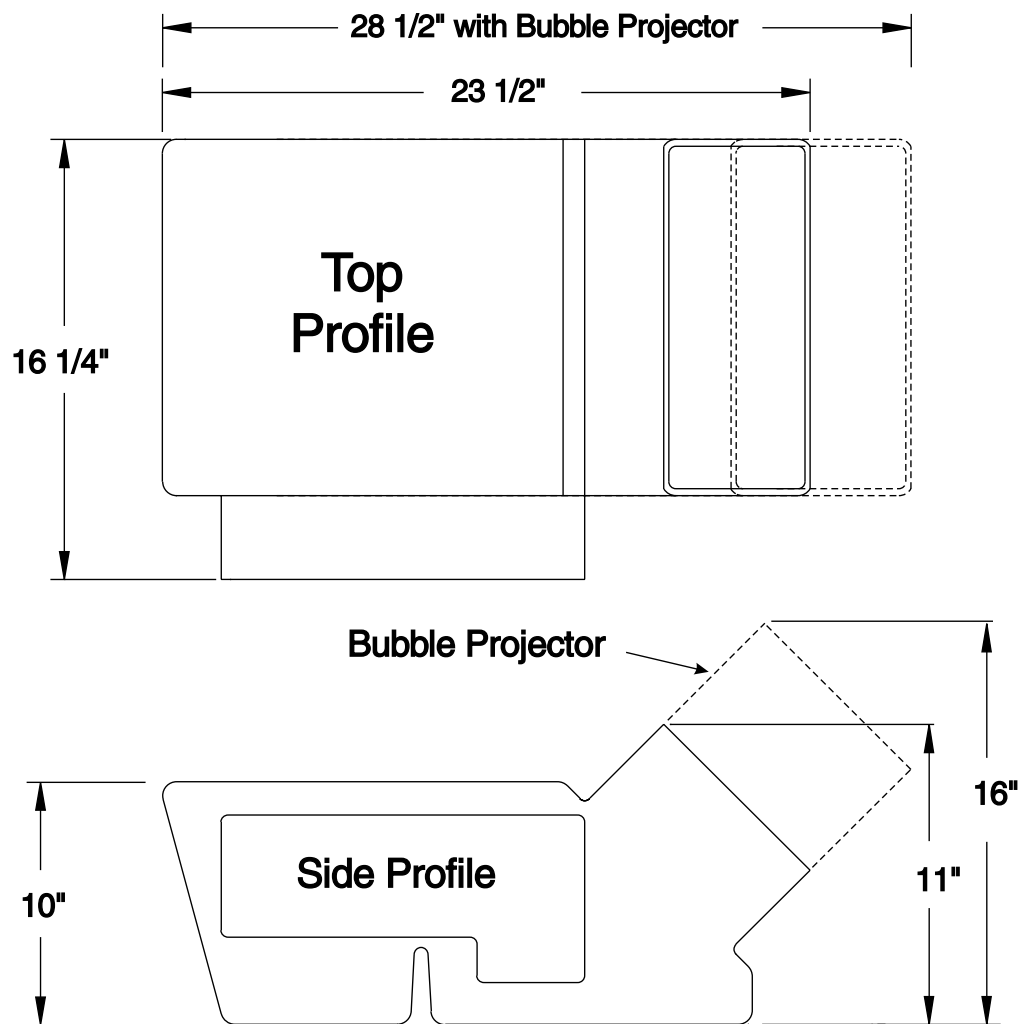

Warning

WARNING
READ THESE IMPORTANT SAFETY INSTRUCTIONS
Do not remove the outer case until power has been
disconnected from the machine

WARNING
Ensure that this unit is grounded at all times.
Failure to do so may result in serious injury.

WARNING
Never use alternative fluids. Toxicity free output
is your responsibility.

M.S.D.S. Available by request or at www.lemaitrefx.com

Operating Procedure

Setup

Unpack the Bubble Master and inspect all components. Although the packaging was designed for the rigours of today's parcel delivery services, damage may have occurred during shipping.

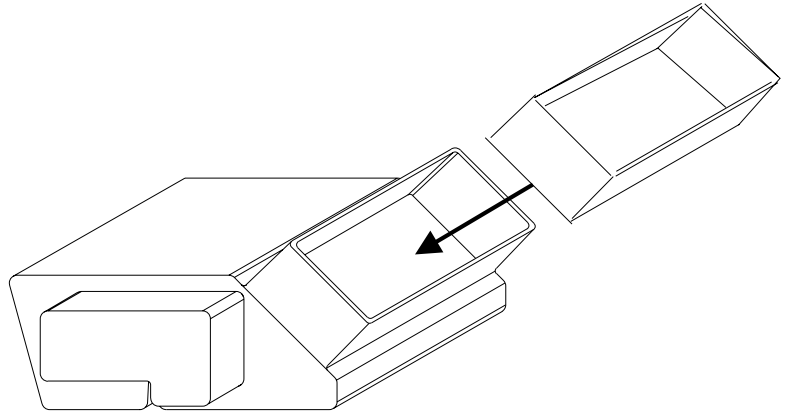

1.) Prior to operation, the extension sleeve may be placed over the bubble outlet. This will allow the bubbles to be projected higher, before they begin to disperse outwards. For lower flying bubbles do not use the extension sleeve.

2.) Place the Bubble Master on a level sturdy surface, or use the optional adjustable stand sold separately.

3.) Open a container of Le Maitre BubbleMaster Bubble Fluid, and pierce the foil top. Pour the fluid into the bubble outlet. Fill up to 1/2" below the reservoir top. This initially should take approximately 1 gallon.

4.) Plug the BubbleMaster into an outlet that is capable of sustaining the current load listed on the product serial plate.

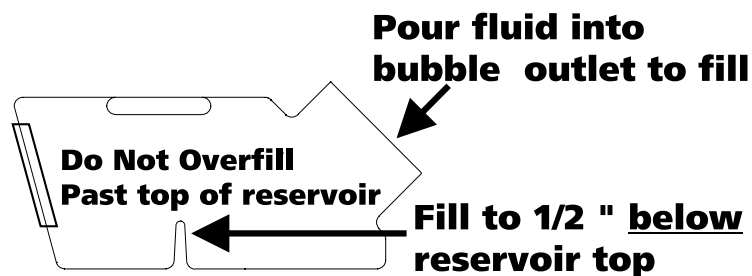

BubbleMaster Controls

1.) Plug the BubbleMaster into a suitable power supply.

2.) Use the Fan Speed Control knob to start the bubble wheel and fans, and to control the fan speed.

By varying the fan speed you can control the bubble volume, size and height.

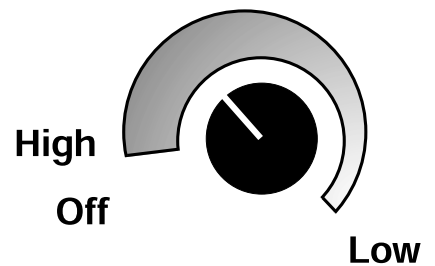

**BubbleMaster Fan
Speed Control**

Recommended Fluid

Use only Le Maitre Special Effects Bubble Master 2000 Bubble Fluid. This biodegradable fluid has been formulated to deliver long lasting “dryer” bubbles that almost dry on contact.

Shut Down Procedure

- 1.) Disconnect the BubbleMaster from the power source.
- 2.) Remove the bubble extension sleeve if used..
- 3.) Using a funnel, empty the contents of the fluid reservoir back into the 1 gallon fluid container. This can be done by tipping the unit, and pouring the fluid out of the bubble outlet.
- 4.) Replace cap on the fluid container to keep dirt and debris from entering.
- 5.) Rinse out fluid reservoir and bubble wheels with hot tap water tap water to remove excess Bubble fluid residue. Using a paper towel wipe out extension sleeve and bubble outlet.

Empty into sink or appropriate drain.

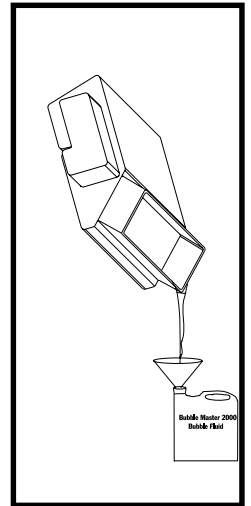

Troubleshooting BubbleMaster

Bubble Wheel not turning:

Ensure that set screws are secure in bubble wheel motor shaft.

Intermittent bubbles produced.

Ensure that there is enough fluid in the fluid reservoir, and that the bubble wheels are being submersed in bubble fluid.

Maintenance

Fluid Reservoir

When storing the Bubble Master for any extended period, be sure to thoroughly rinse the fluid reservoir.

Bubble Wheels

When storing the Bubble Master for any extended period, be sure to thoroughly rinse bubble wheels.

Safety Precautions

1. Ensure that operation of the machine is supervised by suitably trained and authorised personnel.
2. Do not modify the machine or use a machine which has been damaged in any way.
3. Allow sufficient air circulation around the machine at all times.
4. Protect the BubbleMaster from direct weather effects and wet locations.
5. Use only Le Maitre Special Effects Bubble Master bubble fluid.
6. Avoid direct bubble output continuously at persons, structure or objects within close proximity of the discharge nozzle.
- 7.) Do not allow any liquid to spill into or on the remote control or the cover behind the remote.

Warranty

Warranty:

All warranty is one year parts and labour unless specified and is on manufacturer defect only. Overuse or poor maintenance is not accepted. Le Maitre fluids must always be used. Accept no substitutions as there are no exceptions to this rule. Proof of purchase or proof of sale must always accompany any warranty returns. An RA (return authorization) number must be noted on the outside of any box returned to our facilities. Any packages without a clearly marked RA number will not be accepted by our receiving department. Freight on warranty items are freight prepaid to our facility and we will prepay freight back to your facility after repair, by the most economical means available. Should you require the item express-returned, then you are responsible for any difference in freight cost.

Return Policy:

Return of any product must be done within 30 days of purchase. The package must be returned freight prepaid and the RA number clearly marked on the outside of the box. A restocking charge of up to 25% may be levied. Only credits are issued to the dealers account. Any product not returned within 30 days is considered purchased.

Warning:

Le Maitre Special Effects Inc. considers all it's product to be safe for use in the application it was intended. Le Maitre Special Effects takes no responsibility for misuse or incorrect use. Always refer to equipment owners manual for proper use.

Accessories

Model	Description
CLF 2944	DMX Interface
CLB 2005	Bubble Stand Mounting Plate
CLB 2007	Bubble Machine Stand
CLB 2004	Bubble Wall Mounting Plate
CALL	Bubble Machine Hanging Bracket
CLB 2004	Bubble Securing Bracket
CLB 2006	Bubble FDS Option
CLF 3100	20 L. Pail Hanging Bracket
CPH PC001	5 Pin DMX/Bubble Remote Cable 25'
CPH PC005	5 Pin DMX/Bubble Remote Cable 50'
CPH PC007	5 Pin DMX/Bubble Remote Cable 100'

Notes